

User manual
Hoof trimming crush
SA0049 / SA0049B



Manufacturer:

Wopa Constructiebedrijf B.V.
Rector Hulshofstraat 10
7135 JV Harreveld
The Netherlands

: +31-(0)544 372415
: +31-(0)544 372445
Email: info@wopa.com
Website: www.wopa.com

© Copyright 2026

No part of this publication may be reproduced, stored in a search system or transferred in any form whatsoever, either electronically or mechanically, or by photocopying or recording, or in any other way whatsoever without prior written consent from Wopa Constructiebedrijf B.V. (hereinafter in this manual also referred to as "Wopa").

Introduction

Wopa Constructiebedrijf B.V. specialises in development and manufacture of hoof trimming and treatment crushes for cows and bulls for professional users as well as for cattle farmers.

Our crushes are developed and manufactured in the highest possible quality, according to the strictest requirements as far as safety, user convenience, animal welfare and hygiene are concerned, always striving for an optimum.

This manual contains information and instructions relevant to installation, operation and maintenance of the machine.



- The machine is not suitable for use in explosive hazardous environments.
- All persons responsible for operation must, at minimum, read and comprehend the sections on operation and safety of these operating instructions.
- All persons responsible for assembly, installation, maintenance and/or repair must read and comprehend all these operating instructions.
- The user is responsible for interpretation and use of this manual under all conditions. Should you have any doubts or questions regarding the correct interpretation, please contact the owner or the supervisor.
- Keep this manual nearby the installation and within the users' reach.
- Keep a log of all major maintenance work, adaptations to the installations and observations, see Annex 8.1.
- Changes to the installation/machine are not permitted without prior written approval from the supplier.
- Contact the supplier for any special maintenance work not included in this manual.
- Comply with the safety requirements as given in Section 3 at all times.
- Proper functioning as well as the safety of the system can only be guaranteed if the recommended maintenance is carried out correctly and on time.

Manufacturer/Supplier: WOPA Constructiebedrijf BV
 Address: Rector Hulshofstraat 10
 Postal code/Town: NL-7135 JV Harreveld
 Telephone: +31(0)544 372415
 E-Mail: info@wopa.com

Machine name: Claw treatment crush
 Year of construction: 2026
 Type number: SA0049B
 Serial number: 00..

WOPA	Rector Hulshofstraat 10		www.wopa.com		CE	
	NL-7135 JV Harreveld		info@wopa.com			
	The Netherlands		Tel: +31 544 37 24 15		UK	
Type	SA0049B	Machine	Claw Treatment Crush			CA
Serial no.	xxxxx	Watts	... kW	Hz 50		
Total weight	xxxxx kg	Voltage	... V	Year ... 2026		



Warranty

The warranty is subject to the following limitations. The warranty period for products supplied by Wopa is 12 months from the date on the purchasing document. The warranty is limited to production and material errors and therefore does not cover any breakdowns due to a part of the product exposed to any type of wear. Normal wear as can be expected from using this product is therefore excluded.

1. Wopa's responsibility remains limited to replacing defective parts; we recognise no claims to any other type of loss or costs.
2. The warranty is automatically void in case of overdue or poorly implemented maintenance.
3. Should you have any doubts regarding maintenance work or should the machine fail to operate correctly, contact the supplier.
4. The warranty does not apply if the defect is the result of incorrect or negligent use or of maintenance carried out contrary to the instructions in this manual.
5. The warranty is void if any repairs or adaptations are made to the product by third parties.
6. Defects ensuing from damage or accidents caused by external factors are excluded from the warranty.
7. If we replace any parts in accordance with the obligations ensuing from this warranty, the parts we replaced become our property.

Table of Contents

INTRODUCTION	4
WARRANTY	6
TABLE OF CONTENTS	7
DECLARATION OF CONFIRMITY (COPY)	8
OVERVIEW OF SYMBOLS	9
PICTOGRAMS	10
1. TECHNICAL INFORMATION	11
2. DESCRIPTION OF THE INSTALLATION	11
2.1. DESCRIPTION OF THE MAIN COMPONENTS SA0049	12
2.2. ELECTRICAL INSTALLATION	13
2.3. HYDRAULIC INSTALLATION	17
3. SAFETY	19
3.1. GENERAL	19
3.2. DURING NORMAL USE	20
3.3. OPERATING PERSONNEL	20
4. INSTALLATION	21
4.1. LOCATION	21
4.2. CONNECT THE MACHINE.	24
4.3. PREPARING FOR TRANSPORTATION.	24
4.4. COUPLING TO THE TRAILER	24
5. OPERATION	26
5.1. STARTING UP	26
5.2. EMERGENCY STOP	26
5.3. PRODUCTION	27
5.4. HOOK UP THE FRONT LEG	28
6. MAINTENANCE	29
6.1. MAINTENANCE DIAGRAM	30
6.2. CLEAN THE MACHINE.	31
6.3. LUBRICATION OF REAR GATE	31
6.4. CHECK OIL LEVEL/REPLACE OIL	32
6.5. CHECK PLAY IN THE WHEELS	33
6.6. CHECK THE SHAFT BOLTS	34
7. DISPOSAL AS WASTE	35
8. APPENDIX	36
8.1. LOGBOOK	36
LIJST MET AFBEELDINGEN	
FIGURE 1 OVERVIEW SA0049	12
FIGURE 2 OVERVIEW ELECTRIC INSTALLATION	14
FIGURE 3: WIRELESS REMOTE CONTROL (OPTION)	16
FIGURE 4 OVERVIEW OF THE HYDRAULIC INSTALLATION	18
FIGURE 5 DETAILS OF CONVERSION FROM TRANSPORT SET-UP TO WORKING SET-UP (SA0049)	22
FIGURE 6: DETAIL OF HOOKING UP FRONT LEG	28
FIGURE 7: LUBRICATION OF REAR GATE	31
FIGURE 8: HYDRAULIC FLUIDS TO BE USED	32
FIGURE 9: DETAILS OF SHAFT BOLT TORQUE SETTINGS	34

DECLARATION OF CONFIRMITY (COPY)

(In according with EN-ISO/IEC 17050-1:2010)

Manufacturer: Wopa Constructiebedrijf B.V.
Adress: Rector Hulshofstraat 10
NL-7135 JV Harreveld
The Netherlands
☎: +31-(0)544 372415
E-mail: info@wopa.com
Website: www.wopa.com



Declare that:

Machine: Hooftrimming crush
Type number: SA0049B
Serial number: ...

is in conformity with the relevant UK Statutory Instruments (and their amendments):

- 2008 No. 1597 The supply of machinery (Safety) Regulations 2008 (including safety requirements of The Electrical Equipment (Safety) Regulations 2016 No. 1101)

And where applicable

- 2016 No 1091 The Electromagnetic Compatibility Regulations 2016

Following (parts of) harmonized standards are applied:

- EN-ISO 12100:2010
- EN-ISO 13854:2019
- EN-ISO 13849-1:2016
- EN-ISO 60204-1:2018

Technical documentation can be applied for at the above address through management department.





The Netherlands - Harreveld,
Date: _____

J.W.A. Wopereis
Directeur

A handwritten signature in blue ink, appearing to read 'J.W.A.', with a long horizontal flourish extending to the right.











Overview of symbols

The following symbols are used for all actions that jeopardise the safety of the user and/or technician and require caution.

	Attention!
	Hazard: High voltage!
	Hazard: High temperature!
	Tip: Offers quick insight or tips to carry out certain actions more easily and simply.

Pictograms

A number of pictograms and alerts are affixed to the installation to indicate possible risks to users, among other things.

Pictogram	Description	Location
	<ul style="list-style-type: none"> Type plate 	<ul style="list-style-type: none"> On the machine frame
	<ul style="list-style-type: none"> Read the user manual Wear safety goggles when operating machine Wear hearing protection when operating machine. 	<ul style="list-style-type: none"> On the machine frame
	<ul style="list-style-type: none"> The presence of unauthorised persons within turning range of the box is strictly prohibited. 	<ul style="list-style-type: none"> On the machine frame
	<ul style="list-style-type: none"> Warning pictograms System under pressure. 	<ul style="list-style-type: none"> On either side of the frame
	<ul style="list-style-type: none"> Warning pictograms for mechanical and electrical hazards 	<ul style="list-style-type: none"> On the machine frame
	<ul style="list-style-type: none"> Warning pictogram Snagging hazard for hand 	<ul style="list-style-type: none"> On the machine frame
	<ul style="list-style-type: none"> Warning pictogram Never walk under the load during hoisting. 	<ul style="list-style-type: none"> On the machine frame
	<ul style="list-style-type: none"> Crushing hazard 	<ul style="list-style-type: none"> By the rear gate, if present.
	<ul style="list-style-type: none"> Warning pictogram Electrical hazards. 	<ul style="list-style-type: none"> On the machine frame
	<ul style="list-style-type: none"> Warning pictogram Snagging hazard for foot. 	<ul style="list-style-type: none"> On the machine frame
	<p style="text-align: center;">ATTENTION!</p> <ul style="list-style-type: none"> Check regularly whether the pictograms and signs are still clearly recognisable and legible. Replace if this is no longer the case. 	

1. Technical information

	SA0049	SA0049B	
General			
Ambient temperature during operation	- 10 to 40	- 10 tot 40	°C
Noise production	< 75	< 75	dB(A)
Machine dimensions			
Length	2100	2100	mm
Width	1750	1500	mm
Height	2000	2000	mm
Maximum product dimensions			
Length	3290	2000	mm
Width	1750	1250	mm
Height	2400	2250	mm
Electrical connection			
Power supply	Standard / option 1 phase / 3 phase	Standard / option 1 phase / 3 phase	-
National voltage	230/400	230/400	V
Required fuse	8.7/5.9	8.7/5.9	A
Connected value	1.5/2.5	1.5/2.5	kVA
Hydraulic installation?			
Maximum operating pressure	120	145	bar
Tank volume	5.5	9	litre
Type of oil	See Figure 8	Zie 6.4	
Data for road transport			
Axial load	750	-	kg
Maximum drawbar load	100	-	kg
Coupling	ISO 55 mm	-	-
Connection plug	7 or 13	-	pole
Tyre pressure	2,9	-	bar
Wheel bolt torque	110	-	Nm

* see electrical diagram

* If the box is fitted with a 230V plug, the plug must be connected to a wall-mounted socket protected by a residual current operated circuit-breaker (always according to the local regulation in effect). (30mA)

2. Description of the installation

	<p>FUNCTION</p> <ul style="list-style-type: none"> • This section gives an overview of the most important components and functions. If detailed information is available elsewhere in the manual, you are referred to the specific sections. • The design of your crush may differ from the figures below.
---	---

2.1. Description of the main components SA0049

	<p>FUNCTION</p> <ul style="list-style-type: none"> • The SA0049 was developed especially for dairy cattle and beef cattle hoof trimming. • Version SA0049 is equipped with an axle with a draw bar and is suitable for transport on public roads.
---	--

The main components of the crush are shown in the illustration below:

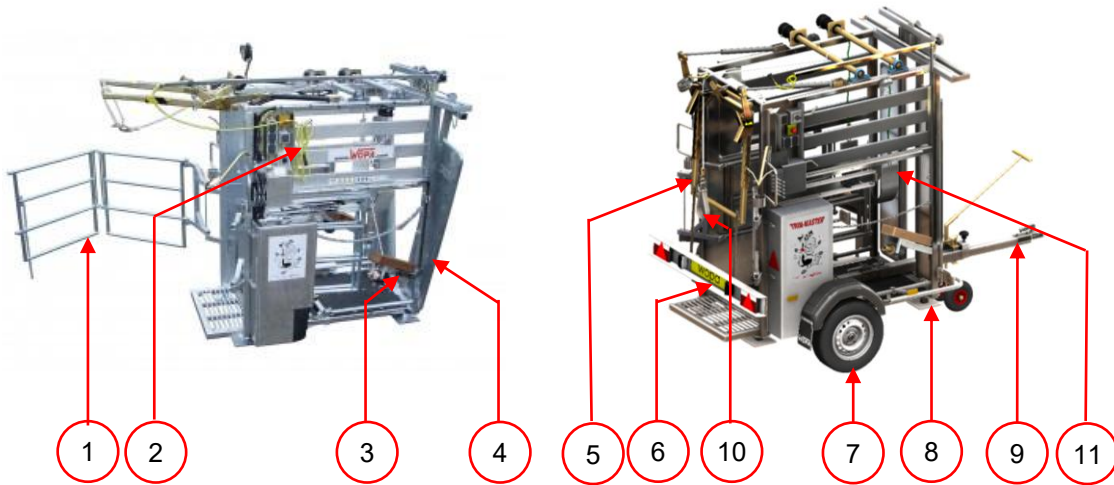



Figure 1 Overview SA0049

	Component	Description	See Section
1	Folding gate	<ul style="list-style-type: none"> • The standard version includes a folding gate for guiding the cattle. 	

	Component	Description	See Section
2	Electrical connection cable	<ul style="list-style-type: none"> The crush must be connected to the electricity network for power supply for operation and the hydraulic power unit. 	
3	Front leg support	<ul style="list-style-type: none"> The cow's front leg can be secured to the front leg support by means of a hydraulic winch so the leg can be treated. 	5.4
4	Front gate	<ul style="list-style-type: none"> The front gate can be set to 3 positions with the hydraulic controls: Entirely open: the cow can exit the crush at the front. Partially open: the cow can move its head through the front gate but not its shoulders. Stationary position. Closed: the front gate is closed behind the animal's head. 	-
5	Hydraulic rear gate	<ul style="list-style-type: none"> Once the cow is moved into the crush, the rear gate is placed lightly against the back of the animal. 	
6	Transport set (light bar) (SA0049)	<ul style="list-style-type: none"> A light bar with a license plate is attached to the crush for transport on public roads. 	
7	Transport set (axle) (SA0049)	<ul style="list-style-type: none"> An axle with mudguards is attached to the crush for transport on public roads. 	
8	Support jacks	<ul style="list-style-type: none"> The 4 support jacks are used to place the crush on the ground. 	
8.1	Lift (Option SA0049B)	<ul style="list-style-type: none"> As an option, instead of 4 mechanical support jacks, the SA0049B can be equipped with 4 hydraulically operated support jacks to easily raise the crush to the desired working height 	
9	Transport set (draw bar arm) (SA0049)	<ul style="list-style-type: none"> A draw bar arm is attached to the crush for transport on public roads 	
10	Hind leg (hydraulic)	<ul style="list-style-type: none"> After the belt is attached round the hind leg, the leg can be lifted with the hydraulic winch so the hoof can be treated. 	
11	Belly strap (hydraulic)	<ul style="list-style-type: none"> Once the cow is moved into the crush, the belly strap is lifted hydraulically behind the front legs. 	

2.2. Electrical installation

	<p>FUNCTION</p> <ul style="list-style-type: none"> • The electrical installation supplies the power for the hydraulic power unit, lighting and sockets. • See the electrical diagram in the control panel of every crush for the rest of the structure and controls of the electrical installation included in the delivery. • The placement of the control components on your installation may differ from the photo below.
---	--

	<p>ATTENTION!</p> <ul style="list-style-type: none"> • Work on the electrical installation can only be carried out by a technical expert.
---	---

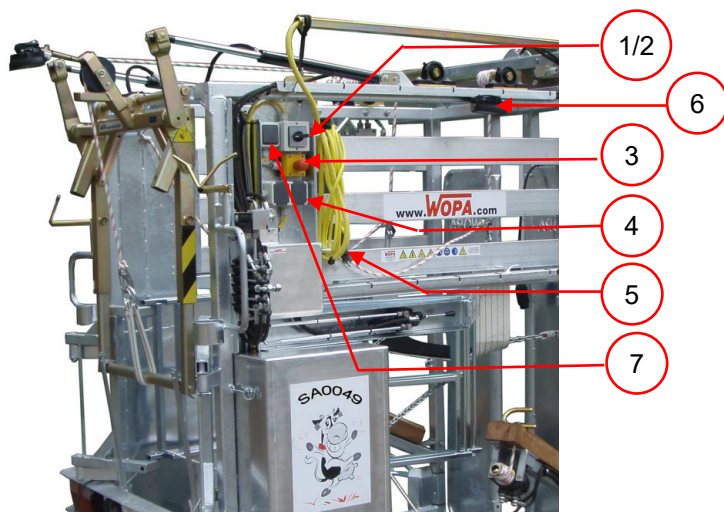

Figure 2 Overview electric installation

The installation consists of the following components

	Component	Description	Section / location
1	Power unit start/stop button	<ul style="list-style-type: none">Pushing the button switches the power unit on or off.	
2	Three-phase current switch	<ul style="list-style-type: none">This switch is only present if the controls are suitable for 3-phase current (option).The switch must be set to position 1 or 2, depending on the direction of rotation of the power network one wants to connect to. The hydraulic power unit can only pump oil in 1 of these positions. If no oil is being pumped, the switch must be flipped immediately to prevent damage to the installation.	
3	Emergency stop	<ul style="list-style-type: none">The emergency stop switches off all operations.	
4	Sockets	<ul style="list-style-type: none">The grinders can be connected to these.	
5	Power supply cable	<ul style="list-style-type: none">To connect the machine to the power supply.	
6	Lights	<ul style="list-style-type: none">These allow the working area to be illuminated.	
7	Lighting switch	<ul style="list-style-type: none">Allows the lights on the crush to be switched on/off	

Wireless remote control (option)



	FUNCTION
	<ul style="list-style-type: none">• The wireless remote control is an option.• The number of function keys (6, 8 or 10) depends on the number of machine functions to be controlled.• The assignment of the various machine functions to the function keys is set up specifically for the customer.



Figure 3: Wireless remote control (option)

2.3. Hydraulic installation

	<p style="text-align: center;">FUNCTION</p> <ul style="list-style-type: none">• The various functions are driven by means of the hydraulic installation• See the hydraulic diagram for a detailed description of the installation.• The placement of the control components on your installation may differ from the photo below.
---	--

	<p style="text-align: center;">ATTENTION!</p> <ul style="list-style-type: none">• Work on the hydraulic installation can only be carried out by a technical expert.
---	--

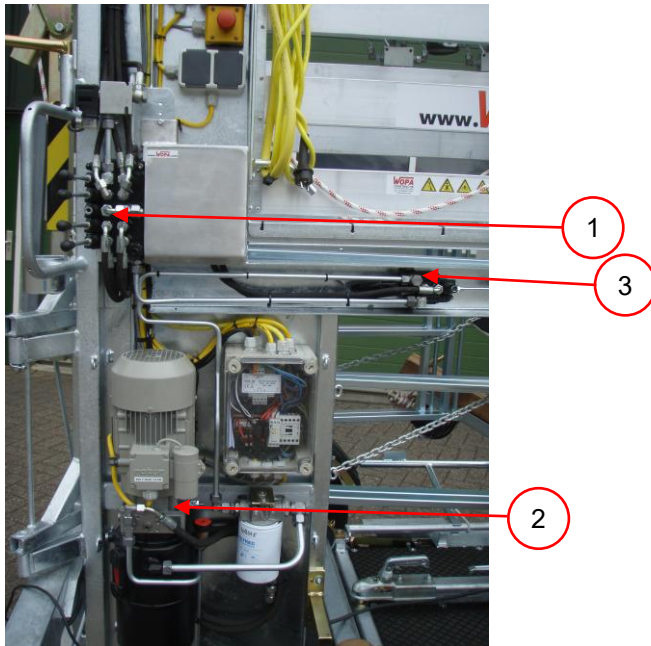



Figure 4 overview of the hydraulic installation

Figure 4	Component	Description	Section / location
1	Valve block in general	<ul style="list-style-type: none"> The valves control the following functions: <ul style="list-style-type: none"> Hind legs Front gate; When closing, it is stopped in the catch position in which the head can be inserted through the gate. Hydraulic shaft Belly strap Rear gate 	
2	Power unit	<ul style="list-style-type: none"> See the type plate on the motor to connect the machine to the power supply. 	
3	Front leg valve	<ul style="list-style-type: none"> It operates the front leg winch. As an option, the crush can be equipped with a hydro-motor on each side. 	

3. Safety

3.1. General

	<ul style="list-style-type: none">• The guarantee will lapse and no liability will be accepted in the event of damage caused by repairs and/or modifications not authorised by the supplier.• In the event of faults please contact the supplier.• The working area around the installation must be safe. The owner of the installation must take the necessary precautionary measures in order to operate the installation safely.• Starting up the installation in an area with a risk of explosion is prohibited.• The installation has been so designed that production is safe under normal ambient conditions.• The owner of the installation must ensure that the instructions in this manual are followed in practice.• The safety features provided must not be removed.• Correct operation and safety of the system can only be guaranteed where maintenance is carried out correctly and in good time, as prescribed.• Where work is to be carried out on the installation it must be disconnected from the power supply, the power supply must be locked off and the system must be depressurised.• There is a risk of trapping when operating driven moving parts. It is the operator's responsibility to ensure that the installation is only started up when no parts of his own or other people's bodies are in the vicinity of the trapping zone.• Ensure that the weight distribution of the towed crushes is not changed. If the weight distribution between left and right sides and/or front and rear (too high or low nose load) is disturbed, this may lead to instability on the road or during use.• It is not permitted to go under a crush raised with a lift. If there is a fault in the installation, the crush could come down.
	<ul style="list-style-type: none">• Only authorised persons appointed by the owner may carry out work on the electrical installation.• Ensure by means of internal procedures and supervision that all applicable power supplies have been switched off.• The installation must not be used during cleaning, inspection, repairs or maintenance, and must be disconnected from the electrical supply by means of the plug and/or the main switch.• Welding work must not be carried out on the installation unless the cable connection to the electrical components has first been disconnected.• The power supply to the control cabinet must not be used for the connection of machinery other than the hand tools provided for.

3.2. During normal use

	<ul style="list-style-type: none">• Check before commencing operations that no work is being carried out on the installation and that it is ready for use.• Unauthorised persons must not enter the operational area of the installation. It is the operator's task to check this.• Components of the hydraulic system may reach high temperatures. Contact with these components may cause injury.
---	---

3.3. Operating personnel

	<ul style="list-style-type: none">• Operating personnel must be aged 18 or above.• Only authorised persons may carry out work with or on the installation.• Only work for which proper training has been received must be carried out. This applies both to maintenance activities and normal use.• The operating personnel must be familiar with all potential situations, so that rapid and effective action can be taken in an emergency.• Where a member of operational staff observes defects or risks or is not in agreement with the safety measures, this must be reported to the owner or the manager.• Safety footwear is mandatory.• Suitable work clothing is mandatory.• All employees must observe the safety instructions to avoid presenting a risk to themselves and others. Comply strictly with the operating instructions at all times.
---	--

4. Installation

	<p style="text-align: center;">EXPLANATION</p> <ul style="list-style-type: none">• Consult the technical data and the circuit diagram provided for the correct specifications.
---	---

4.1. Location

	<p style="text-align: center;">CAUTION</p> <ul style="list-style-type: none">• The machine must be transported and installed upright.• Place the machine on a level and stable non-slip substrate.• Take account of the instructions in Section 3 when carrying out any activity. Failure to follow these may lead to serious injury.
---	--

	<p style="text-align: center;">UITLEG</p> <ul style="list-style-type: none">• This section describes fitting the SA0049 with a wheel set.• If you have an SA0049B (without a wheel set), only items 2, 3 and 12 apply.
---	--

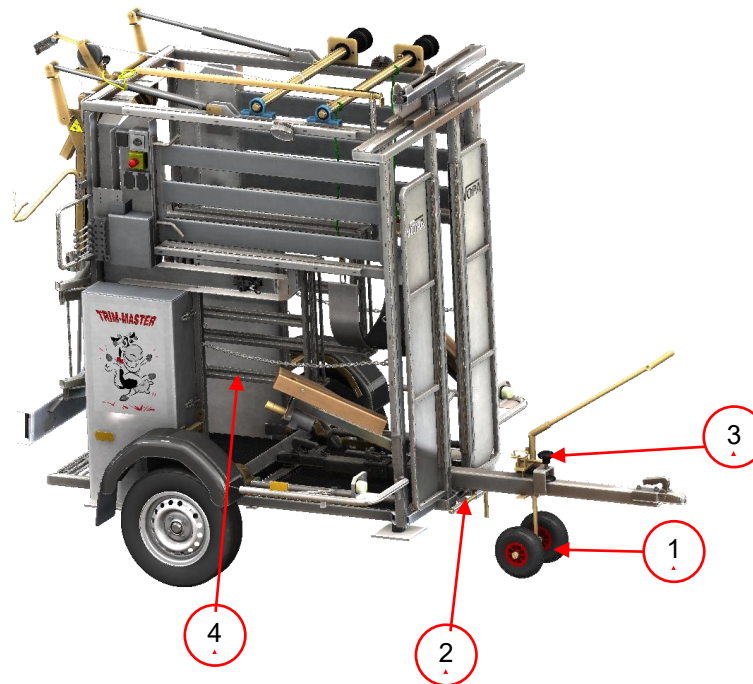



Figure 5 details of conversion from transport set-up to working set-up (SA0049)

No.	What to do	Action	Result
1.	Tip the nose wheel downwards.	<ul style="list-style-type: none"> Ensure that the crush is resting on the nose wheel.(Figure 5 : 1) 	
2.	Connect the crush.	<ul style="list-style-type: none"> See 4.2,5.2 	
3.	Open the front gate.	<ul style="list-style-type: none"> Operate the valve to open the front gate. 	
4.	Remove the mudguards	<ul style="list-style-type: none"> Loosen the locking elements and lift the mudguard out of the adapter. 	
5.	Tip the crush back.	<ul style="list-style-type: none"> Tip the crush to the rear so that the drawbar is clear of the ground. With the rear gate raised the crush will remain in that position. Check that the folding gates are still secured with the front support feet ropes. 	
6.	Remove the locking pin from the drawbar.	<ul style="list-style-type: none"> Rotate the locking pin upwards and remove it. (Figure 5 :2) 	
7.	Free the drawbar.	<ul style="list-style-type: none"> Rotate the locking knob and unlock the clamp situated in the middle of the drawbar, then slide the nose wheel of the crush off until the drawbar comes free from the crush. (Figure 5 : 3) 	
8.	Tip the crush forwards.	<ul style="list-style-type: none"> Lift the rear of the crush so that it tips forwards. The drawbar now rests on its nose wheel and the ball joint connection in the box. Disconnect the drawbar ball mounting. 	
9.	Tip the axle.	<ul style="list-style-type: none"> Lift the axle cylinder locking mechanism. Operate the valve until the wheels are folded up. 	

10.	Remove the drawbar.	<ul style="list-style-type: none">Remove the drawbar from the crush and store it out of the way. The shaft will be held upright by the elastic cord attached to the ball mounting.	
11.	Remove the lighting board.	<ul style="list-style-type: none">Remove the lighting board from the crush.	
12.	Install the side gates.	<ul style="list-style-type: none">Withdraw the side gates from the crush and place them in the desired position. (Figure 5 : 4)	

4.2. Connect the machine.

	<p>CAUTION</p> <ul style="list-style-type: none"> • Check that the voltage specified on the machine plate matches the mains supply. • The machine must always be connected to an earthed socket to avoid the risk of fire or electric shocks (the earth connection is coded green/yellow). • The electrical installation including the sockets must be connected in accordance with local regulations. • The power cable must always be free and nothing must be placed on top of it. • Replace the power cable immediately if it is damaged.
---	--



4.3. Preparing for transportation.

	<p>CAUTION</p> <ul style="list-style-type: none"> • Preparing for transportation is the reverse procedure to making ready for use (see 4.1). • With crushes equipped with an axle and drawbar it is essential that all locking mechanisms are correctly installed.
--	--

4.4. Coupling to the trailer

The trailer coupling head is equipped with a safety check indicator. The following refers to different positions and colour fields.



Marking	Coupling position	Handle position	Meaning
	Coupling is open	Handle is pulled up	WARNING The trailer must NOT be driven.
	Coupling is closed	Handle is in the starting position	The trailer may be driven.
	Wrong position	Handle is in the starting position	WARNING The trailer must NOT be driven.

Uncoupling.

- Pull up the ball handle and swing it forward until the pointer remains in the red field with the cross (X position).
- The trailer may not be driven after this point.
- CAUTION! Do not insert fingers into the opened trailer coupling head!
- Even a slight pressure on the ball cap can activate the locking mechanism and lead to the fingers being injured.

Coupling.

- The trailer coupling head should be in the open X position and placed on the ball of the towing vehicle after which it engages audibly.
- The pointer in the green field is now in the + position.
- After coupling, the pointer should always be used to check that the trailer coupling head is correctly locked to the ball.
- If the pointer is in the green field (+ position) then the coupling is correctly closed and there is still sufficient wear reserve.
- CAUTION! Only in this case is a secure connection made between your vehicle and the trailer and it is permitted to drive on the open road.
- Attach the breakaway cable to the ball neck and connect the plug to the vehicle's socket. Release the handbrake from its lock.
- STOP! When the pointer is in the red field (- position), the coupling is incorrectly closed and the trailer may NOT be driven under any circumstances.
There can be three causes for this.
 1. The ball on the vehicle is already very worn and does not provide the trailer coupling head with sufficient grip.
 2. The trailer coupling head itself is very worn and no longer provides sufficient grip on the ball. In this case, the trailer coupling head must be replaced.
 3. The locking mechanism of the trailer coupling head was activated, but there is no ball in the coupling. The trailer coupling head is loose on the ball and not connected. In this case, open the trailer coupling head as previously described and try again.
- CAUTION! When the pointer is in the red field and - position, the trailer coupling head is not closed. Under no circumstances should the trailer then be driven.
- The locking mechanism may be stiff due to lack of lubrication. In this case, lubricate the mechanism and try again.

General

- The maximum permissible swivel range of the trailer coupling head in relation to the vehicle axis is 25°.
- In the horizontal direction, turning angles in a range of approximately 20° are possible.
- CAUTION! If the turning ranges are exceeded, the components are overloaded and the function of the trailer coupling head is no longer guaranteed.
- The handle of the trailer coupling head indicates its permissible nose load.
- STOP! A trailer should not be driven with a negative nose load as it affects driving stability.
- A negative nose load can easily be changed by moving the load on the trailer.
- The installation, repair, adjustment and conversion work of drawbar eyes or trailer coupling heads may only be carried out by qualified garages.
- CAUTION! To ensure optimal driving and braking behaviour of the trailer, it is essential that the coupling heights of the towing vehicle and trailer match. According to DIN74058, the position of the coupling point on the trailer should be about 35mm above the point where the wheel is on the ground. To check the coupling height, the trailer and towing vehicle must be exactly horizontal and loaded to the full permissible weight.

5. Operation

	<p>CAUTION</p> <ul style="list-style-type: none"> Take account of the instructions in Section 3 when carrying out any activity. Failure to follow these instructions may lead to serious injury.
---	---

5.1. Starting up

No.	What to do	Action	Result
1.	Switch on the power.	<ul style="list-style-type: none"> Insert the plug in the socket. 	
2.	Reset the emergency stop.	<ul style="list-style-type: none"> Pull out the emergency stop buttons. 	The control unit is now ready for use.
3.	Switch off the electricity	<ul style="list-style-type: none"> After working, always remove the power plug from the electrical outlet. 	

5.2. Emergency stop.

	<p>CAUTION</p> <ul style="list-style-type: none"> The emergency stop button must always be pressed in in the event of an emergency. All motions will cease following operation of the emergency stop button. In order to take the machine back into use after an emergency stop the emergency stop button must first be reset. Before resetting the emergency stop button it must be ensured that restarting the moving parts of the machine will not lead to a hazardous situation.
---	--

- Reset the emergency stop**

No.	What to do	Action	Result
1.	Reset the emergency stop button.	<ul style="list-style-type: none"> Reset the emergency stop button by pulling it out or rotating it (depending on the type installed) so that it returns to its original position. 	The machine is now ready for use.

5.3. Production

No.	What to do	Action	Result
1.	Check that the crush is ready for use.	<ul style="list-style-type: none"> See Sections 5.1 and 5.2. 	
2.	Place the front gate ready.	<ul style="list-style-type: none"> Open the front gate so that the head of the animal can pass through but not its withers. When the front gate is closed hydraulically it will stop at the correct position and the handle can be released. This means that the holding position is always the same. 	
3.	In order to	<ul style="list-style-type: none"> Lead the cow into the crush until its head has passed through the front gate. Close the front gate. 	
4.	Bring the rear gate into position.	<ul style="list-style-type: none"> Lower the rear gate. In order to avoid the risk of damage to the front legs, ensure that the rear gate is NOT pressed up tightly against the animal. 	
5.	Raise the belly belt.	<ul style="list-style-type: none"> Bring the belly belt up under the belly of the cow. 	
6.	Process a rear hoof.	<ul style="list-style-type: none"> Place the belt around the rear leg and raise the leg. Process the rear hoof. Allow the leg to drop and release it. 	
7.	Process a front hoof.	<ul style="list-style-type: none"> Attach the front leg with the hook as shown in Figure 6. Operate the winch hydraulically until the leg is tight up against the block. Process the front hoof. Release the rope. 	See 5.4
8.	Lower the belly belt.	<ul style="list-style-type: none"> Reverse the winch until the belly belt is on the ground. 	
9.	Release the crush.	<ul style="list-style-type: none"> Check that all ropes and belts have been freed. Open the front gate. Lead the cow out of the crush. 	
10.	Place the rear gate in its raised position.	<ul style="list-style-type: none"> Raise the rear gate. 	

5.4. Hook up the front leg.

	<p style="text-align: center;">CAUTION</p> <ul style="list-style-type: none">• The leg can be hooked up in two ways:• With a small hook (see Figure 6:1).• With a large hook (option) (see Figure 6:2).• When hooking up with the small hook, especially with hydraulically driven winches, there is a risk of permanent injury if the front leg is pulled too tight.• When using the large hook, there is no risk of injury from over-tightening.
---	---

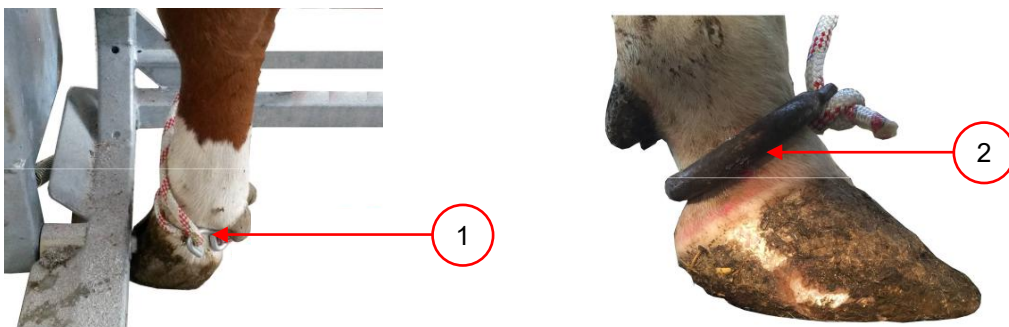

Figure 6: detail of hooking up front leg

6. Maintenance



CAUTION!

- Always disconnect the machine from the power supply by disconnecting the plug. If an accumulator is present, depressurise it.
- Test the installation on completion of maintenance work or repairs to ensure that it can be used again safely.
- Only trained technical personnel may carry out the maintenance activities described or repair work.

6.1. Maintenance diagram

The diagram below shows the maintenance activities to be carried out.

Activity	note	Daily	weekly	Every 100 animals	Annually	Every 2 years	See Section
General							
Check on panic locks and hooks.	Renew where damage is visible.						
Check ropes and chains.	Renew where damage is visible.						
Check plugs, cables, controls and connections.	Alert a competent fitter where damage is visible.						
Check that the left and right front leg ropes are hanging at equal lengths.	Where these are driven by a single motor.						
Cleaning							
Clean the machine.							6.2
Lubrication							
Grease nipples on rear gate sliding section.	Bearing grease.						6.3
Other grease nipples.	Bearing grease.						
Hydraulic installation							
Check the oil level.	Checks must be carried out after 500 cows or where leakage occurs.						6.4
Replace oil and filter.							
Axle and wheels							
Check play in the wheels.							6.5
Check the tyre profile.	Have this inspected by a competent person.						
Check the tyre pressures.	Have this inspected by a competent person.						
Drawbar							
Play in ball mounting.	Replace where minor play is evident, or see markers on the side of the ball mounting.						
Ball and coupling in crush.	Check and clean						
Check the latch.	There must always be slight tension on the latch.						
Check the shaft bolts.	Every 10,000 km.						0

6.2. Clean the machine.

	<p>EXPLANATION</p> <ul style="list-style-type: none"> • A high-pressure cleaner may be used for cleaning. • Avoid bearings, winches and motors when cleaning with a high-pressure cleaner. Spraying in these areas may result in a sharp reduction in service life. • Avoid all electrical components when cleaning with a high-pressure cleaner. Spraying in these areas may result in risk of electric shocks and /or a sharp reduction in service life.
---	---

6.3. Lubrication of rear gate

	<p>EXPLANATION</p> <ul style="list-style-type: none"> • The rear gate is slid out with the aid of gas springs fitted to the gate. • To prevent grease entering the gas springs and causing damage, the gate must only be lubricated when it is fully drawn back.
---	--



1

2

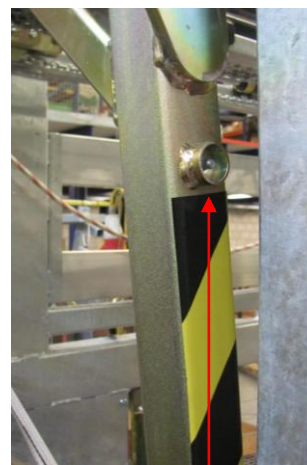

3

Figure 7: lubrication of rear gate

No.	What to do	Action	Result
1.	Retract the rear gate.	<ul style="list-style-type: none"> • Attach the rear leg winch to the rear gate and tighten until the gate is fully retracted. 	
2.	Grease the nipples.	<ul style="list-style-type: none"> • Lubricate the rear gate nipples using a grease gun. 	

6.4. Check oil level/replace oil.

	<p>EXPLANATION</p> <ul style="list-style-type: none"> • Checking the oil level ensures that the necessary minimal amount of oil is present. The cylinders must be retracted for this purpose. • The general rule is that the oil and filter should be replaced year.
---	--

• Gauging the oil level

No.	What to do	Action	Result
1.	Retract the cylinders.	<ul style="list-style-type: none"> • Put the cylinders in the installation in their retracted position by operating the valves. 	
2.	Check the oil level.	<ul style="list-style-type: none"> • The oil level must now be between the minimum and maximum levels (see instructions on "changing the oil"). 	

• Changing the oil

No.	What to do	Action	Result
1.	Bring the oil to the tank.	<ul style="list-style-type: none"> • See the instruction on "gauging the oil level". 	
2.	Empty the tank	<ul style="list-style-type: none"> • Remove the plug from the tank and allow the oil to run out until it is empty. 	
3.	Fill the installation.	<ul style="list-style-type: none"> • Fill the tank via the filler cap. 	
4.	Check the oil level.	<ul style="list-style-type: none"> • The oil must be between the two lines on the filler cap dipstick. 	

- The following types of oil are suitable for use in the hydraulic installation:

Supplier	Oil
Castrol	HYSPIN AWH – M 32 / 46
Mobil	UNIVIS N 32 / 46
Q8	HANDEL 32 / 46
Q8	HELLER 32 / 46
Texaco	RANDO 32 / 46
Texaco	HYDRAULIC OIL HDZ 32 / 46
Total	EQUIVIS ZS 32 / 46
Valvoline	100 ULTRAMAX HVLP 32 / 46
Petronas	HYDRAULIC HV 32 / 46
Gulf	HARMONY HVI 32 / 46
Shell	TELLUS S2 V 32 / 46
Shell	TELLUS T 32 / 46

Figure 8: hydraulic fluids to be used

6.5. Check play in the wheels.

	<p>EXPLANATION</p> <ul style="list-style-type: none"> • This paragraph applies only to versions fitted with a wheel axle and pulling mandrel. • Raise the wheels from the ground and feel if any play is present. • If play can be detected this must be corrected by a competent person, or otherwise the bearings and seals must be replaced.
---	---

	<p>EXPLANATION</p> <ul style="list-style-type: none"> • After the first 50 km, check that all the wheel bolts are still firmly in place. Using a torque spanner, tighten the wheel bolts see chapter 1 for the correct value.
---	---

	<p>EXPLANATION</p> <ul style="list-style-type: none"> • Check the physical condition of the tyres and their tread regularly. • Check the tyre pressure regularly. See chapter 1 for the correct value.
--	---

SA0049						
Variant	B1	B2	B3			
75	X	X	X			
Tyres	Size	Pressure	LI	Rims	ET value	R.dyn.
B1	185/70 R13	300 kPa	90	4.5 / 5 / 5.5 / 6 J x 13	+20 tot/to +35	286 mm
B2	175 R13 C	450 kPa	97	4.5 / 5 / 5.5 J x 13	+20 tot/to +35	295 mm
B3	155 R13	290 kPa	80	4.5 / 5 J x 13	+20 tot/to +35	281 mm
Minimum speed class						
Symbol	Speed					
N	140 km/h					

6.6. Check the shaft bolts.

	<p>EXPLANATION</p> <ul style="list-style-type: none"> • This paragraph applies only to versions fitted with a wheel axle and pulling mandrel. • After 10,000 km or once annually the shaft bolts must be tightened with a torque wrench in accordance with the figure below.
---	---

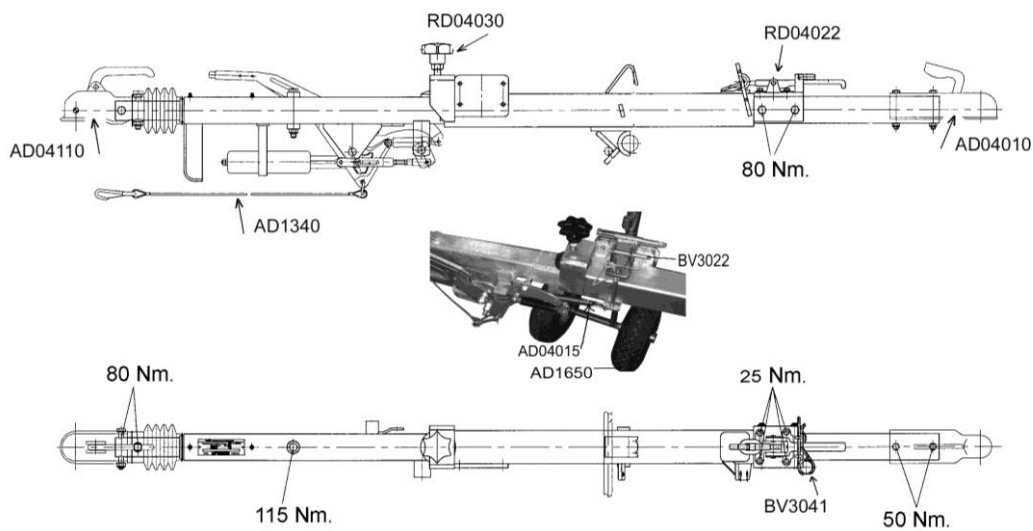

Figure 9: Details of shaft bolt torque settings

7. Disposal as waste

Oil and components must not be disposed of as domestic waste. When replacing components or oil or at the end of the machines service life, ensure that all materials are collected and destroyed or reused in a legal and environmentally friendly manner.



